



OPERATING MANUAL **SM 6**

Lampert Werktechnik GmbH
Eye protection system

Issue EN 2022/05



Product : Welding microscope
Typ: SM 6

Manufacturer: Lampert Werktechnik GmbH
Ettlebener Strasse 27
97440 Werneck
Phone: +49 (0)9722 94 59 – 0
Fax: +49 (0)9722 94 59 – 100
E-Mail: mail@lampert.info
Website: www.lampert.info

Revision index: 4.0
Date of revision: 12.05.2022

Contents

1	About this operating manual	5
1.1	General.....	5
1.2	Presentation of information.....	6
	Handling instructions	6
	Application tip	6
1.3	Structure of the warnings.....	6
2	General safety regulations.....	8
2.1	Principles.....	8
2.2	Intended use	8
2.3	Foreseeable misuse	8
2.4	Safety instructions.....	9
	General information	9
	During transport	9
	During installation/commissioning	9
	During operation.....	9
	Maintenance and inspection work.....	9
	During disassembly	10
2.5	Selection and qualification of personnel	10
2.6	Safety devices.....	10
2.7	Norm conformity	11
3	Structure and function	12
3.1	Functional description	12
3.2	SM 6 microscope	13
	Microscope head	14
	SM 6 stand	15
4	Transport and storage	16
4.1	Transport.....	16

4.2	Storage.....	16
5	Commissioning	17
5.1	Setting up the SM 6 microscope.....	17
5.2	Adjusting the microscope.....	19
5.3	Requirements for the working environment	20
5.4	Establishing supplies.....	20
5.5	Functional test	21
6	Help with faults	22
7	Care and inspection work	23
7.1	Care and inspection schedule	23
7.2	Carry out care and inspection work	23
	Cleaning the lens.....	23
	Replacing the protective glass	23
	Retightening the microscope brake.....	24
8	Disposal and recycling	25
9	Dimensions and technical data	26
9.1	Dimensions of the eye protection system.....	26
9.2	Technical data.....	27
10	Appendix.....	28
10.1	Service address.....	28
10.2	Spare and wear parts	28

1 About this operating manual

Before operating the device for the first time or starting any other work on the device, you are required to read these operating instructions carefully.

Pay particular attention to the chapter 2 "General safety regulations".

1.1 General

These operating instructions are intended to help you get to know the device and use it as intended. They contain important information on how to operate the device safely and properly.

The operating instructions must

- Be fully read and applied by any person assigned to work on the device.
- Be stored in such a way that they are accessible at all times to all users at the place of use of the device.
- Be handed over to third parties together with all necessary documents when the device is passed on.

Observance of the operating instructions helps

- Avoiding dangers.
- Reduce repair costs and downtime.
- Increase the reliability and service life of the machine.

In addition to the operating instructions, the accident prevention and environmental protection regulations applicable in the country of use and at the place of use must also be observed.

1.2 Presentation of information

Handling instructions

The instructions explain step by step which activities have to be carried out and how to proceed.

In these operating instructions, handling instructions are marked with the following symbols:

- The steps marked with this activity symbol may be carried out in any order.
- 1) Numbered steps **must be** carried out exactly in the given order.
- ✓ The result symbol describes the result or intermediate result of an action.

Application tip

The "**TIP**" indicates additional information for easy and safe use of the machine.

TIP: Note on the optimal use of the machine.

1.3 Structure of the warnings

Signal word	Avoidance of ...	Possible consequences if the warning is not heeded:
DANGER	Personal injury (imminent danger)	Death or severe injuries!
WARNING	Personal injury (potentially hazardous situation)	Death or severe injuries!
CAUTION	Personal injury	Light or minor injuries!
NOTE	Property damage	Damage to the device or its immediate surroundings!

Tab. 1.1 Warning levels

The warnings are structured as follows:

- Warning sign with signal word in accordance with the warning level (see Tab. 1.1)
- Type of hazard (description of the hazard)
- Consequences of the hazard (description of the consequences of the hazard)
- Hazard prevention (measures to prevent the hazard)



DANGER!

Type of hazard

Consequences of hazard

➤ Hazard prevention

Warning sign

Special warnings are given at relevant points. They are marked with the following pictograms.



General warning sign

This sign warns of personal injury.

In the case of a clearly identifiable source of danger, it is preceded by one of the following pictograms.



Electrical voltage

Warning of possible electric shock, potentially with fatal consequences.

2 General safety regulations

2.1 Principles

The eye protection system shall be used only when in flawless condition and is intended exclusively for work in accordance with the intended use.

2.2 Intended use

The unit is intended as personal protective equipment for arc welding of weldable metals and alloys with all compatible Lampert precision micro welding devices.

2.3 Foreseeable misuse

- Use of the eye protection system without connecting the connection cable to the device.
- Plugging the connection cable plug of the eye protection system into the electrode grinding motor connection instead of the connection for the personal protective equipment on the welding device.
- Plugging the eye protection system connection cable connector into the foot switch connector instead of the personal protective equipment connector on the welding device.
- Observing the welding process past the protective filter of the microscope.

2.4 Safety instructions

General information

- If the eye protection system shows signs of damage, it must be taken out of service
- If malfunctions occur, the eye protection system must likewise be taken out of service

During transport

When transporting the eye protection system manually, make sure that it does not fall to the ground or get knocked over. In the event of a fall, damage may occur that impairs the function of the eye protection system.

During installation/commissioning

The eye protection system must be set down on a stable and non-slip surface.

The eye protection system must be properly connected to the welding device in order to function properly.

Always carry out a functional test before putting the microscope into operation, see page 21 in chapter 5.

During operation

During the welding process, always look into the microscope such that the eye cups are close to the eyes.

Do not look into the light of the LED lamp on the bottom of the eye protection system with unprotected eyes!

Maintenance and inspection work

The eye protection system should always be covered after use to avoid soiling the oculars.

During disassembly

When dismantling, the connection cable plug must be unplugged from the corresponding socket on the welding device.

2.5 Selection and qualification of personnel

The operator undertakes to only allow persons to work on the device who

- Are familiar with the basic regulations on occupational safety and accident prevention and have been instructed in the handling of the device
- Have read and understood this operating manual, in particular the "General safety regulations" chapter
- Are trained with regard to the requirements for the work results.

The safety-conscious working of the personnel must be checked at regular intervals.

All persons who are instructed to work on the device undertake, before starting work, to

- observe the fundamental regulations governing occupational safety and accident prevention
- confirm with their signature that they have read and understood this operating manual, and in particular the chapter on "safety instructions", and that they will observe this information.

2.6 Safety devices

- An automatic dimming eye protection filter is fitted to the microscope head to prevent eye injury even if the electronically controlled dimming system malfunctions.

2.7 Norm conformity

The manufacturer has developed and tested the eye protection system according to the following relevant legislation and harmonized norms:

- Harmonized norms**
- EN 379:2003/A1:2009 Personal eye-protection – Automatic welding filters
 - EN 166:2001 Personal eye-protection – Specifications

Declaration of conformity

The eye protection system's shutter has been type-examined according to regulation EU 2016/425 Personal protective equipment. The eye protection system itself, however, does not come under EU 2016/425, as the microscope is not worn or held by the user during operation. Therefore, a CE declaration of conformity is not possible. Lampert has nevertheless successfully performed all required and legally possible tests and examinations of EU 2016/425 and the above mentioned norms.

Manufacturer address

Lampert Werktechnik GmbH
Ettlebener Straße 27
97440 Werneck
Germany

3 Structure and function

3.1 Functional description

The eye protection system consists of a microscope and an automatically darkening eye protection filter. The stand with hand rests is used for stable positioning and enables a comfortable body posture for the operator during the welding process.

The eye protection system protects your eyes from UV radiation, which inherently originates during welding. It prevents the cornea from permanent and irreversible impairment.

3.2 SM 6 microscope



Fig. 3.1 SM 6 microscope

1. Microscope head
2. SM 6 stand

Microscope head

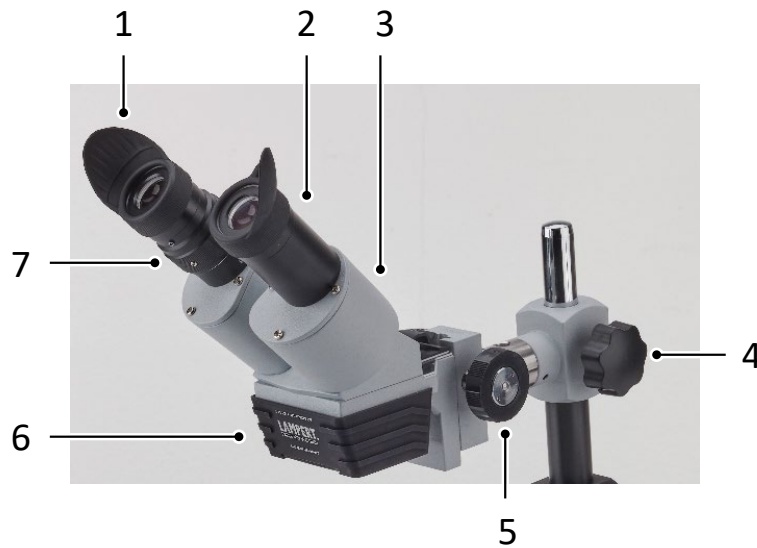

Fig. 3.2 Microscope head

1. Eye cups
2. Oculars
3. Prism housing
4. Microscope head height adjustment
5. Focusing wheel
6. Automatic eye protection filter
7. Dioptr adjustment

Eye cups The eye cups protect the eyes from light reflected off the surroundings during the welding process.

Oculars The oculars are used to enlarge the field of view.

Prism housing The appropriate interocular distance to the ocular can be adjusted on the prism housing.

Microscope head height adjustment The height adjustment on the microscope head allows the welding microscope to be adapted to the working height of the operator.

Focusing wheel The focusing wheel can be used to focus the microscope.

Automatic eye protection filter The automatic eye protection filter serves to protect the eyes during welding by darkening the field of view.

Dioptr adjustment With the dioptr adjustment, the eye protection system can be adjusted to the user's own visual acuity.

SM 6 stand



Fig. 3.3 SM 6 stand

1. Handpiece holding arm with spacer sleeve
2. Base plate with stand rod
3. Screw-in foot for inclination adjustment
4. Hand rests
5. Handpiece holding sleeve with knurled screw

Handpiece holding arm with spacer sleeve

The handpiece of the welding device can be clamped in the handpiece holding arm. The distance sleeve is used to maintain a defined distance between the microscope head and the handpiece holding arm.

Base plate with stand rod

The stand consists of a rod to which the handpiece holding arm and the microscope head are attached. The base plate ensures good microscope stability.

Screw-in foot for inclination adjustment

The screw-in foot for tilt adjustment enables the microscope to be tilted. This provides more comfort during the welding process.

Hand rests

The hand rests provide hand support during welding and support the operator's forearms. This ensures a steady hand position during welding.

Handpiece holding sleeve with knurled screw

The handpiece holding sleeve is used to fix the handpiece in the handpiece holding arm. This allows the workpiece to be easily brought up to the electrode for contacting during the welding process.

4 Transport and storage

4.1 Transport

In principle, the microscope can be carried and transported by hand without any special precautions. For longer transport distances, however, we expressly recommend packing the device in the original box or a similar suitable container. To avoid scratches or damage to the surface, it is also advisable to line transport containers with soft, dry and scratch-free materials (e.g. foam).

4.2 Storage

The storage location of the eye protection system must be dry and dust-free and must not be subject to extreme temperatures (colder than -20 °C or hotter than $+55\text{ °C}$).

To avoid contamination, the eye protection system should be covered during storage.

5 Commissioning

5.1 Setting up the SM 6 microscope

- 1) Remove the packaging completely.
- 2) Remove the microscope head from the stand rod. To do this, loosen the locking screw while holding the microscope head with your hand. Then pull the microscope head upwards off the stand rod.
- 3) Attach four of the rubber adhesive feet supplied to the underside of the base plate.



Fig. 5.1 Attaching the rubber feet to the base plate

- 4) Remove the hand rests from the packaging and mount each hand rest on the top of the base plate using two of the enclosed hexagon socket screws with the supplied Allen key.



Fig. 5.2 Mounting the hand rests

- 5) Screw the screw-in tilt adjustment foot into the bottom of the stand rod. Now the tilt angle of the microscope can be adjusted by screwing the tilt adjustment in or out.



Fig. 5.3 Attaching the tilt adjustment

- 6) Place the handpiece holding arm on the stand rod with the sleeve facing upwards and fix it in place with the locking screw.
- 7) Place the microscope head back on the stand rod and fix it in place with the locking screw.
- 8) Place the eye cups included in the accessory set onto the oculars.

- 9) Connect the connection cable to the socket marked yellow-red on the back of the welding device, see also the operating instructions of the corresponding welding device.
- ✓ Now the microscope is set up correctly and must be adjusted.

5.2 Adjusting the microscope

Align the handpiece holder so that you are able to easily introduce a workpiece with your hands to the tip of the handpiece mounted in the handpiece supporting arm. It should be possible to place both hands and palms on the baseplate hand supports.

Adjusting the interocular distance

Now look through the two oculars and move the ocular tubes by holding the prism housing still and moving them in or out. The interocular distance is correct if the range of vision as viewed through the two oculars is complete and is united into a single image. The interocular distance should be individually set for each user.

Focusing

- 1) Mount a welding handpiece with clamped electrode into the handpiece supporting arm.
 - 2) Position the handpiece holding arm so that you can easily bring the workpiece up to the electrode. Then hand-tighten the locking screw on the handpiece holding arm so that it does not slide down on the stand rod.
 - 3) Slide the microscope head down the stand rod until it rests on the spacer sleeve of the handpiece holding arm.
 - 4) Look through the oculars and move the microscope head up or down using the side-mounted focusing wheel, until the object appears focussed.
- ✓ The focus on the microscope is now set.

Dioptr adjustment The sleeve for adjusting the dioptr is fitted to the left-hand ocular. In the normal position, the lower part of the sleeve is aligned with the marking on the ocular tube.

In the event of differing vision in both eyes: Open the right eye only, look into the right-hand ocular and adjust the focus using the focusing wheel. Now look through the left-hand ocular with your left eye and adjust the focus by turning the dioptr control on the left tube until the image appears focused.

5.3 Requirements for the working environment

- The device shall not be used outdoors.
- The device shall be used in dry rooms only.
- The device must be placed on a level (maximum angle of inclination 10°), stable and insulated surface.

5.4 Establishing supplies



Fig. 5.4 Connection cable with plug

The circular connector for the eye protection system and the LED lighting is inserted in the connecting socket marked in yellow/red on the rear side of the Lampert fine welding device and tightened with the union nut until hand tight.

Always observe the operating instructions for the Lampert fine welding device connected.

5.5 Functional test

Check the function of the eye protection filter. To do this, connect the eye protection system to the welding device. Press the button for the eye protection test in the settings menu of the welding device. This must darken the field of vision. This can be checked by looking through the oculars. If the button for the eye protection test is pressed again, the LED illumination must be visible again when looking through the oculars.

6 Help with faults

No.	Fault	Possible cause	Fault rectification / solution
1	The LED illumination fails to operate	Cable not connected	Connect the plug to the connection socket marked with the red and yellow eye protection / lamp symbol on the PUK.
		LED faulty	Contact customer service
2	Eye protection system no longer works	Cable connected incorrectly	Connect the plug to the socket marked with the red and yellow eye protection / lamp symbol on the device.
		Eye protection filter faulty	Arrange to have eye protection unit replaced by qualified personnel.
3	Poor resolution	Oculars dirty	Clean oculars
4	Marks or soiling in field of vision	Oculars dirty	Clean oculars
		Protective glass dirty	Clean or exchange protective glass
5	Focus is not retained	The sight slides down	Readjust the tension of the focusing wheel

Tab. 6.1 Causes of errors and fault rectification

7 Care and inspection work

7.1 Care and inspection schedule

Interval	Care and inspection work	Comments
Daily	Check working environment	Clean if necessary
	Check the condition and cleanliness of the machine	Clean if necessary
	Cover the microscope after working.	
As required	Clean the lens	
	Clean the protective glass	Use a soft cotton cloth moistened with glass cleaner.
	Replace the protective glass	
	Retighten the microscope brake	Sickle spanner required for this is included

Tab. 7.1 Care and inspection schedule

7.2 Carry out care and inspection work

Cleaning the lens

Remove dust with a soft brush, then clean with a soft cloth (not a microfibre cloth) in circular motions from the centre outwards

Replacing the protective glass

To replace the protective glass, slide it forward out of the holder and replace it with an original replacement protective glass.

Retightening the microscope brake

- 1) Slightly loosen the slotted screw on the focusing wheel, but do not unscrew it completely.



Fig. 7.1 Opening the microscope brake

- 2) Apply the sickle spanner and tighten the ring on the focusing wheel to tighten the microscope brake.

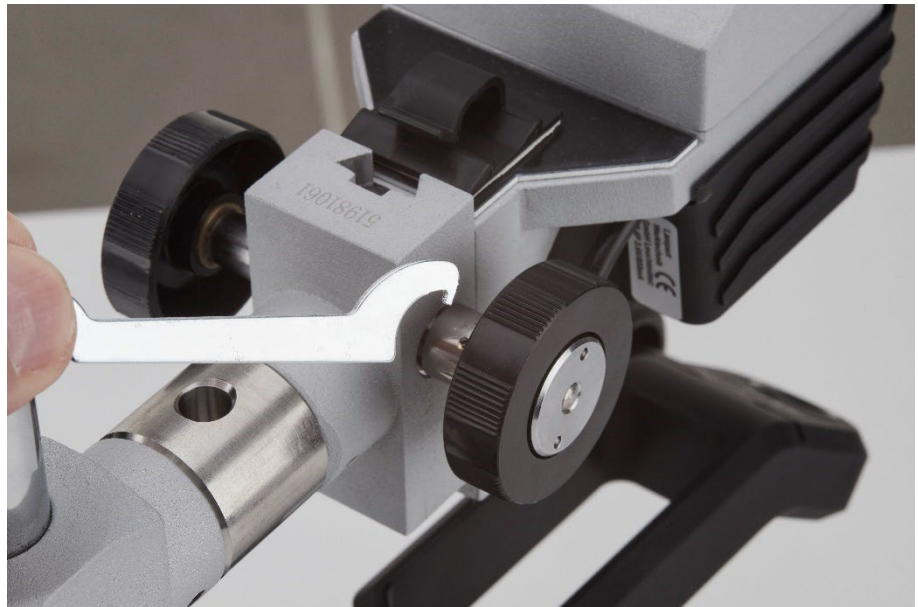

Fig. 7.2 Releasing the microscope brake

- 3) Tighten the slotted screw again.
- ✓ The microscope brake works again and the microscope head holds its position on the stand rod.

8 Disposal and recycling



Render discarded devices unusable by removing the mains cable.



Only for EU countries: In accordance with European directive 2012/19/EU regarding the disposal of used electrical and electronic equipment, discarded electrical devices must be separated and collected and sent for recovery in an environmentally friendly manner

9 Dimensions and technical data

9.1 Dimensions of the eye protection system

Name		Value	Unit
Weight		3.5	kg
Dimensions	Length	260	mm
	Width	280	mm
	Height	470	mm

Tab. 9.1 Microscope dimensions

9.2 Technical data

Name		Value	Unit
Electrical connection			
Voltage (supply)	Shutter	12	V
	LED	5	V
Frequency		50	Hz
LED power consumption		4	W
Max. current strength LED		800	mA
Optical data			
Working distance		140	mm
Magnification factor		10x	
LCD shutter			
Light shade		DIN 3	
Dark shade		DIN 11	
Switching time		< 50 ms	
UV protection		> UV 11	
IR protection		> IR 11	
General data			
Max. operating temperature		+5 to +40	°C
Max. outside temperature	Transport/storage	-20 °C up to +55 °C	°C
	Operation	-10 °C up to +40 °C	°C
Relative humidity		0 – 80 % non-condensing	
Risk category acc. to 2016/425/EU		II	
Protection category acc. EN 379:2003 [6]		3/11 LWT 1/1/1/2/379	

Tab. 9.2 Technical data for the welding microscope

10 Appendix

10.1 Service address

If you have any problems with your eye protection system, please contact your Lampert partner company or the Lampert dealer from whom you purchased the device.

In the event that you have not purchased the device via an authorised Lampert partner company or are unable to locate one, please contact the manufacturer directly:

Lampert Werktechnik GmbH
Ettlebener Strasse 27
97440 Werneck
Germany
+49 9722 9459 0
mail@lampert.info

10.2 Spare and wear parts

Only original spare and wear parts may be used for your SM 6. These are listed in the Lampert spare parts catalogue and on the manufacturer's website.



Lampert Werktechnik GmbH
Ettlebener Strasse 27
D-97440 Werneck (Germany)
Telephone: +49 (0)9722 94 59-0
Fax: +49 (0)9722 94 59-100
email: mail@lampert.info
Website: www.lampert.info

All contents of these operating instructions, in particular text, photographs and graphics, are protected by copyright. The copyright is held by Lampert Werktechnik GmbH, unless expressly stated otherwise.

Lampert Werktechnik GmbH reserves the right to change this documentation and the descriptions, dimensions and technical data contained therein without prior notice.

We would like to point out that these operating instructions may only be reproduced for internal purposes and that their contents must remain unchanged. The content may not be made available to third parties and may not be used for purposes other than those for which it was intended.

© Copyright remains with Lampert Werktechnik GmbH.